

4-2017

Family Influence on Chinese International Students' Sense of Coherence

Yiwen Zhang

University of Minnesota, Morris, zhan4217@morris.umn.edu

Follow this and additional works at: http://digitalcommons.morris.umn.edu/urs_2017



Part of the [Higher Education Commons](#), and the [Psychology Commons](#)

Recommended Citation

Zhang, Yiwen, "Family Influence on Chinese International Students' Sense of Coherence" (2017). *Undergraduate Research Symposium 2017*. 8.

http://digitalcommons.morris.umn.edu/urs_2017/8

This Book is brought to you for free and open access by the Undergraduate Research Symposium at University of Minnesota Morris Digital Well. It has been accepted for inclusion in Undergraduate Research Symposium 2017 by an authorized administrator of University of Minnesota Morris Digital Well. For more information, please contact skulann@morris.umn.edu.

Family Influence on Chinese International Students' Sense of Coherence

Yiwen (Ophelia) Zhang

Outline

- Background
- Goal of Current Study
- Methods
- Final model and Results
- Discussion

Outline

- Background
- Goal of Current Study
- Methods
- Final model and Results
- Discussion



Background: Statistics

2015/16: China Top origin country for international students in the U.S. (Institution of International Education, 2017).

representing **31.5 %**

increasing **8.1 %** between 2014/15 and 2015/16 to **328,547**





Background: Sense of Coherence (SOC)

❖ The extent to which one regards one's life as:

- a. Comprehensive**
- b. Manageable**
- c. Meaningful**

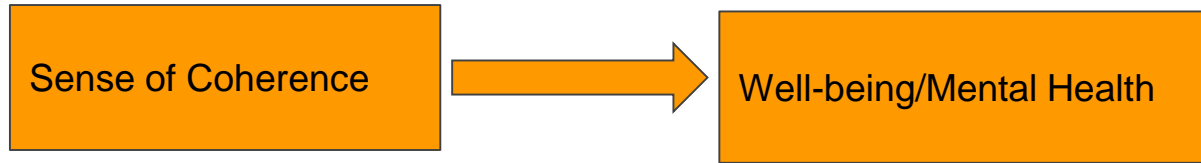



Background: Adaptation Process

Depression and **Maladaptive Behaviors** triggered by

Difficulties of language, social interaction, and learning style

Cultural Differences



Background: Family relationship

Healthy family relationships lead to

Better well-being

Higher self-esteem

Better sense of comprehensibility and manageability



Outline

- Background
- **Goal of Current Study**
- Methods
- Final model and Results
- Discussion

Goal of current study

Examine how Family Relationship and Adaptation process effect SOC levels in Chinese international students during their first crucial months in the U.S.



Hypotheses

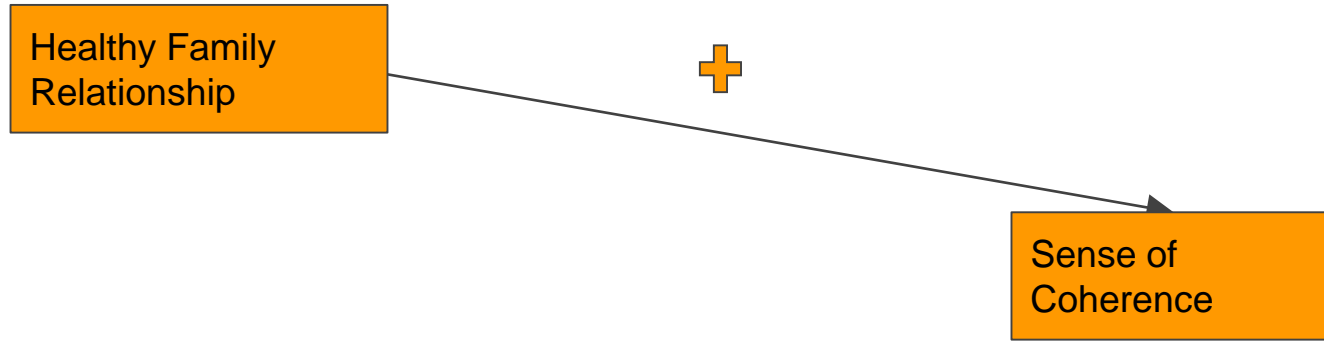

Hypotheses

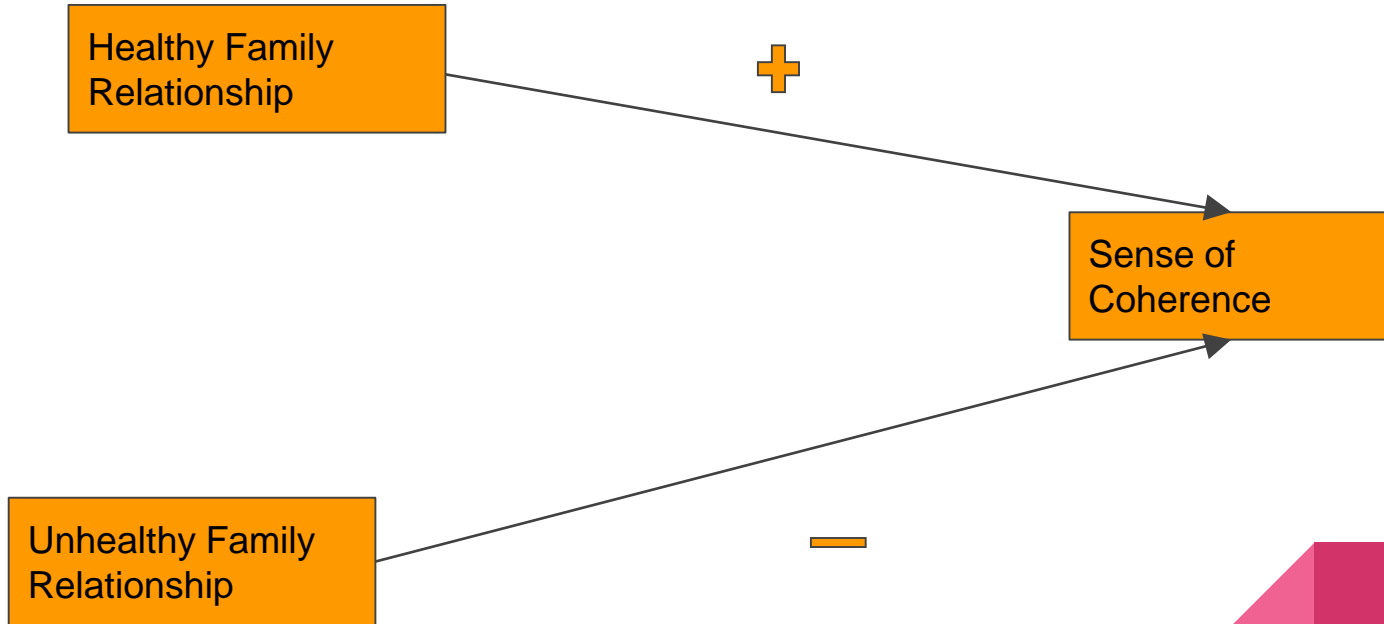

Hypotheses

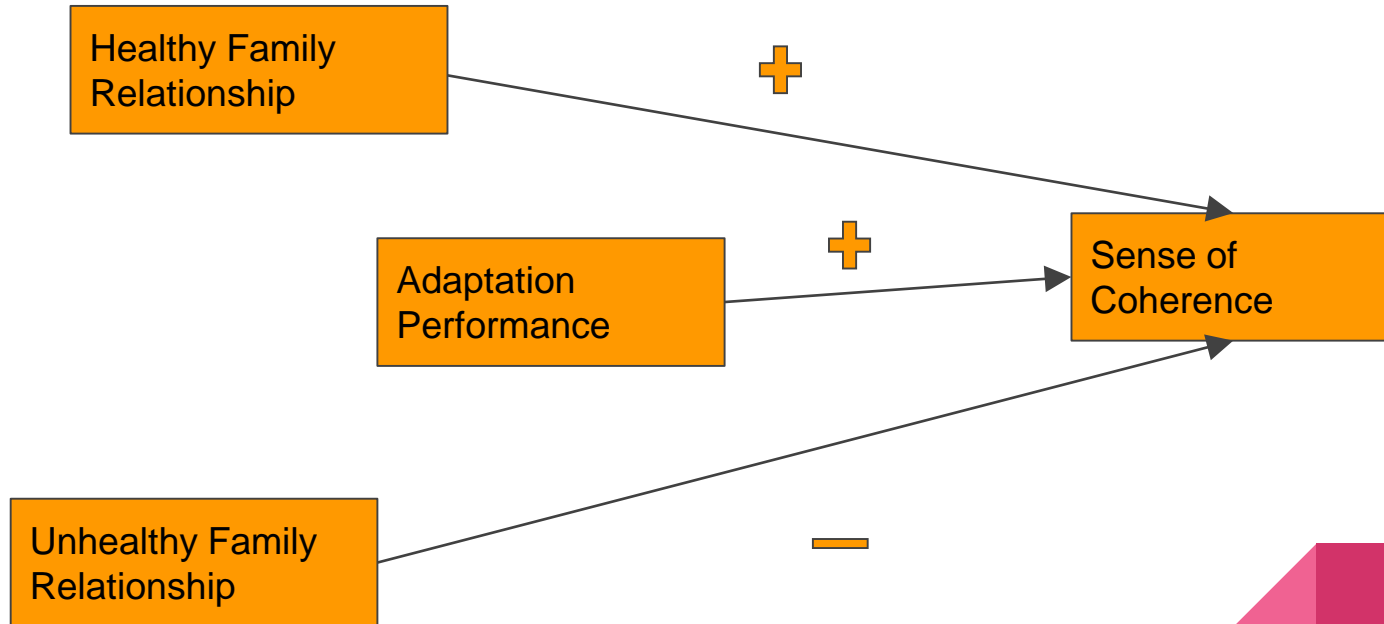

Hypotheses

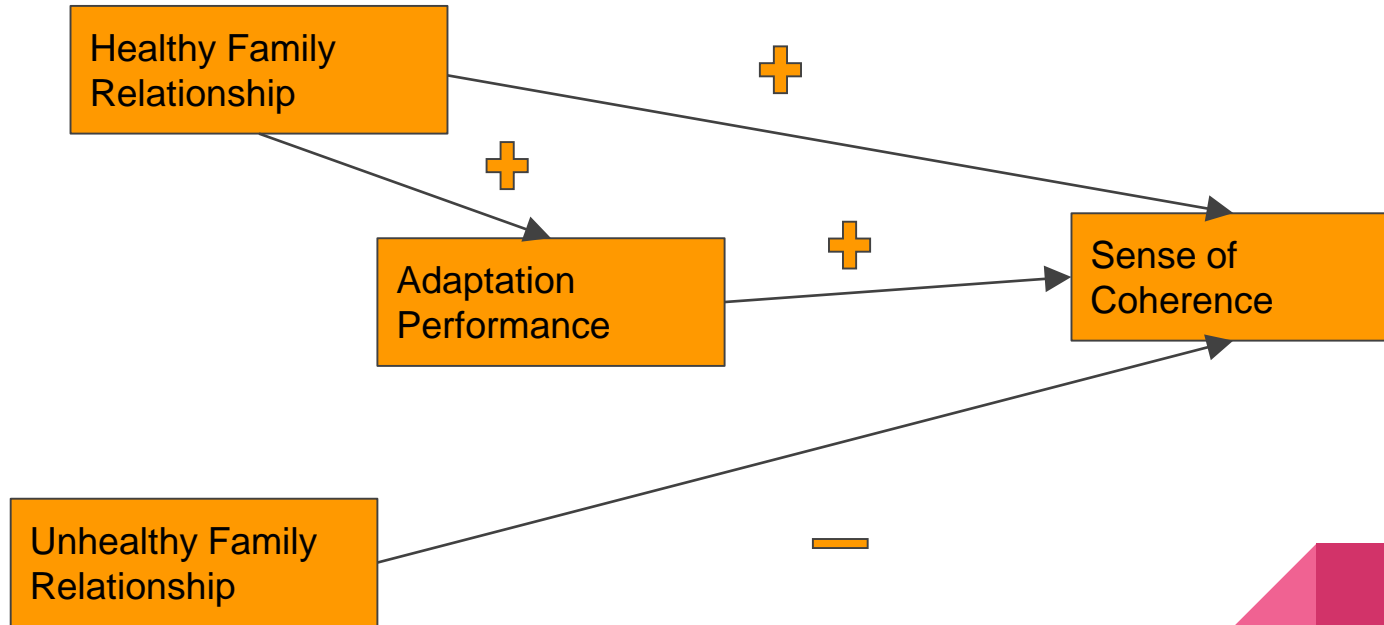



Hypotheses: Time 1: Beginning of adaptation

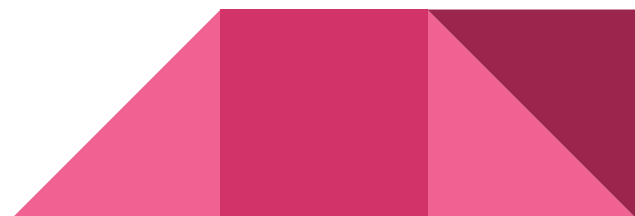
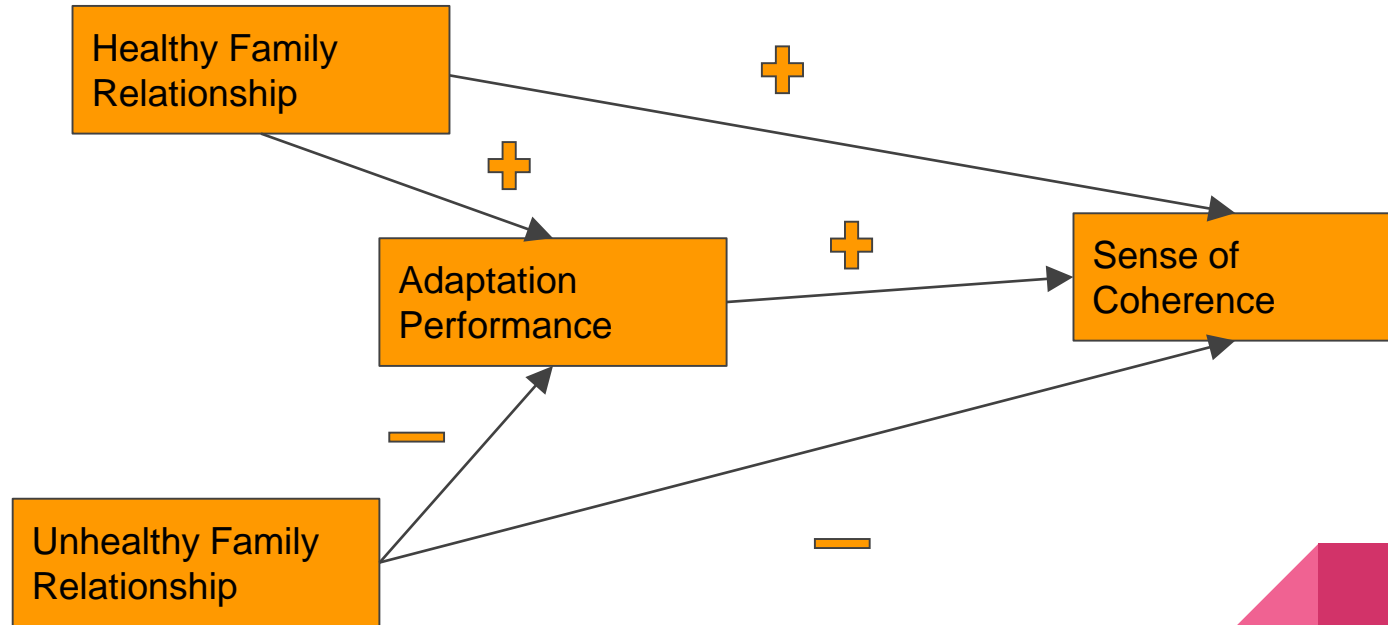



Hypotheses: Time 2: After a few months of Adaptation

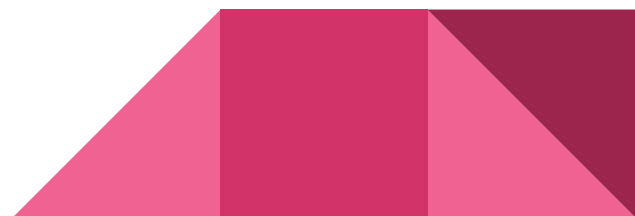
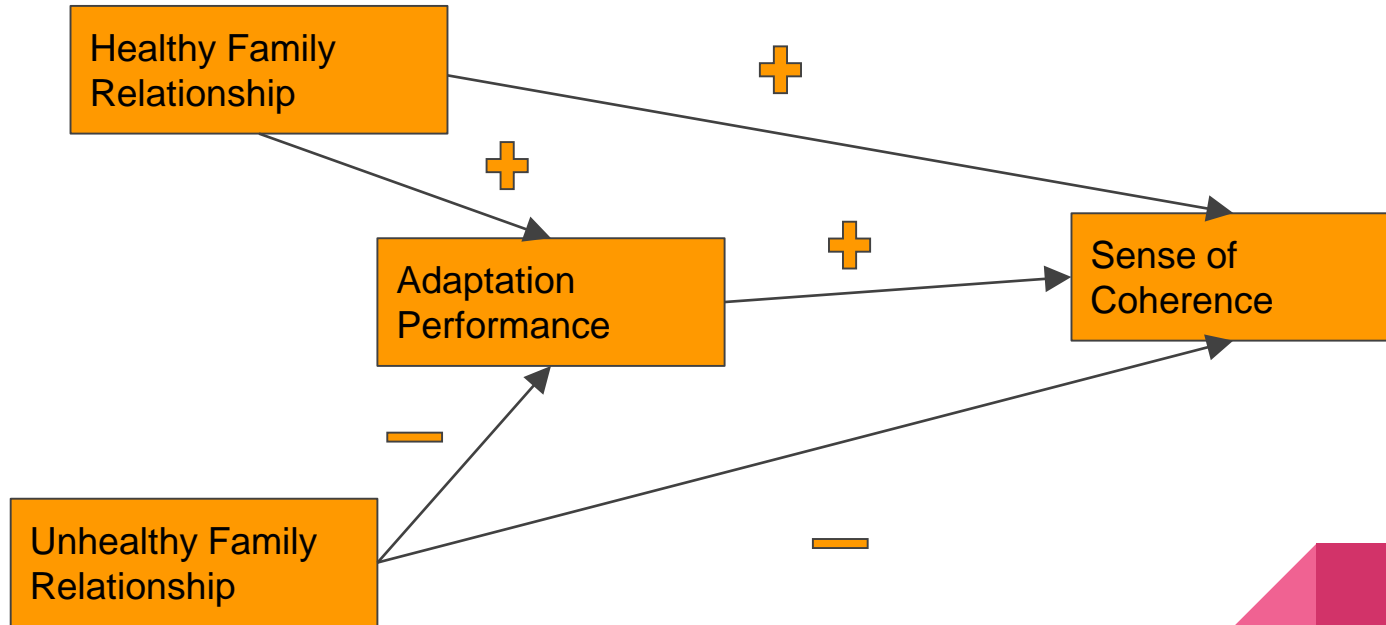



Hypotheses: Time 2: After a few months of Adaptation

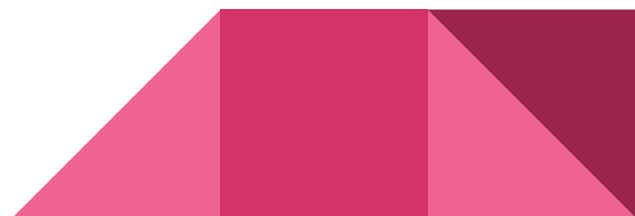
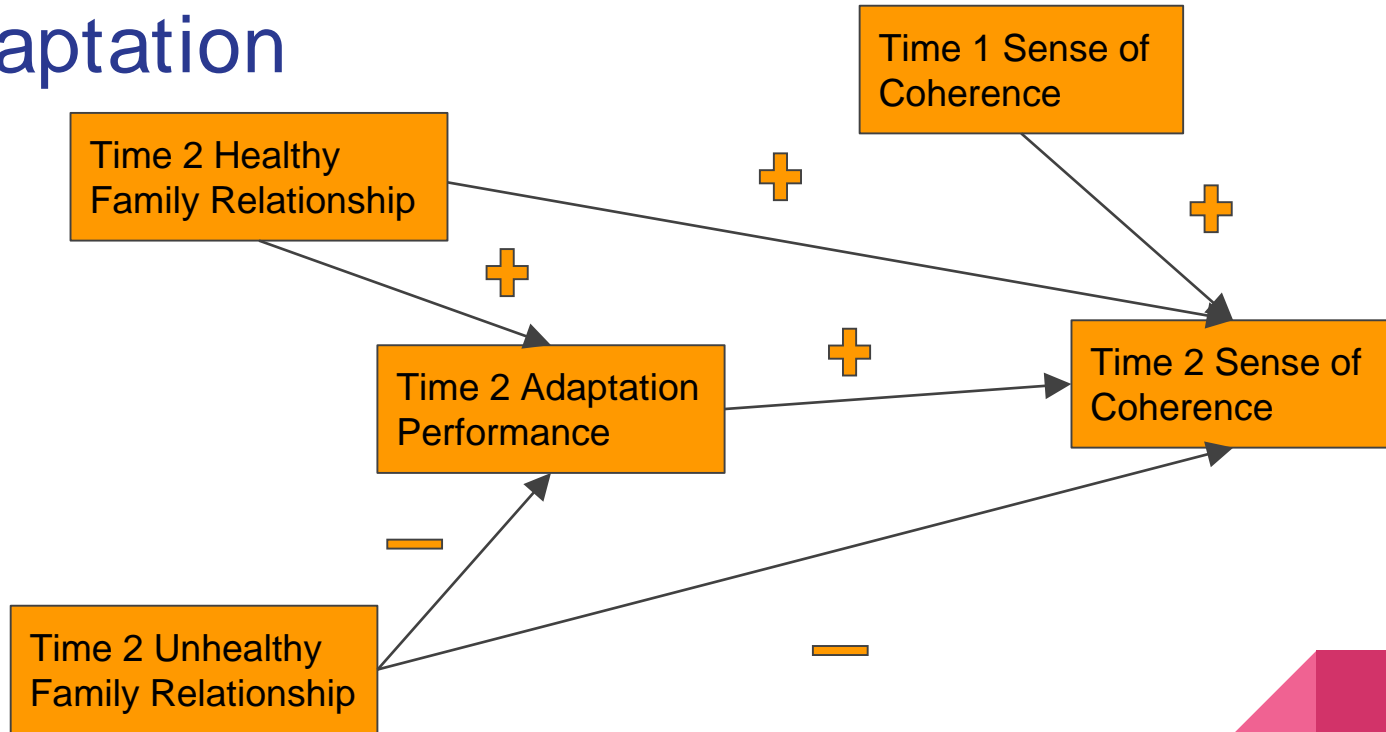

Outline

- Background
- Goal of Current Study
- **Methods**
- Final model and Results
- Discussion

Method

Participants

Data Collection

Measures

Analysis



Method

- Participants
 - 43 First year Chinese International Students from UMM
 - 34 of them remained in the whole study
- 2 Data collections: **Same online questionnaires**
 - Time 1: Beginning of Fall
 - Time 2: End of Fall

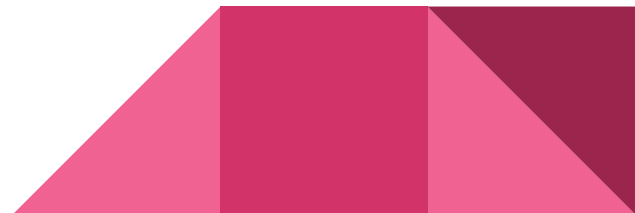

Method: Questionnaires

1. *Sense of Coherence Scales* (Antonovsky, 1987)

23 items (e.g., 1=Very often; 7 =Very seldom or never)

3 components:

Comprehensibility: “**Does it happen that you have the feeling that you don’t know exactly what’s about to happen?**”

Manageability: “**How often do you have feelings that you’re not sure you can keep under control?**”

Meaningfulness: “**How often do you have the feeling that there’s little meaning in the things you do in your daily life?**”

Method: Questionnaires

2. *Family Adaptability And Cohesion Evaluation Scales* (Olson, Gorall, & Tiesel, 2004),

62 items; Likert scale: 1 (strongly disagree) to 5 (strongly agree).

8 subscales: Balanced cohesion, Balanced flexibility, Disengaged, Enmeshed, Rigid, Chaotic, Communication, and Satisfaction.

(Healthy) Balanced flexibility: **“When problems arise, we compromise”**

(Unhealthy) Chaotic: **“We never seem to get organized in our family”**

(Healthy) Communication: **“Family members try to understand each other’s feelings”**

Method: Questionnaires

3. ***Sociocultural adaptation Scale*** (SCAS; Ward, & Kennedy, 1999).
 - 41 items; Likert scale: 1 (Not Difficult) to 5 (Extremely Difficult)
 - Measurement of intercultural competence
 - E.g., “**Understanding humor**”
 - $\alpha = .945$
 - Reverse coded



Reminder: Hypotheses

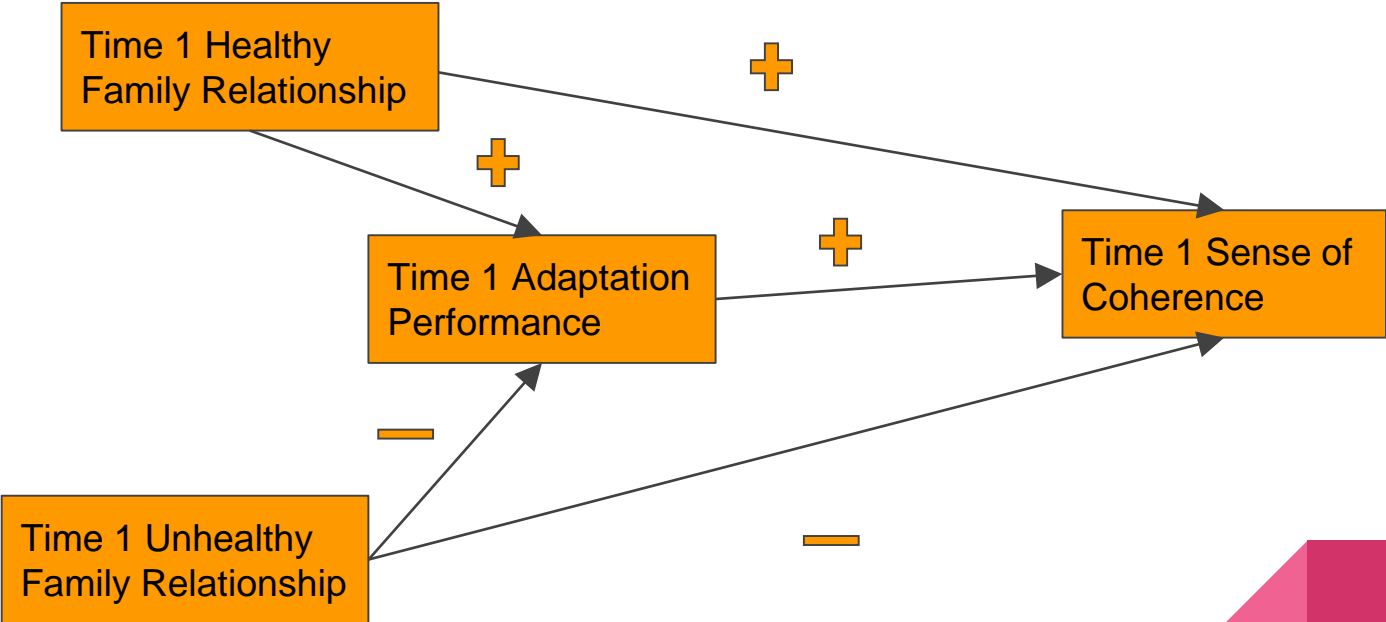

Reminder: Hypotheses

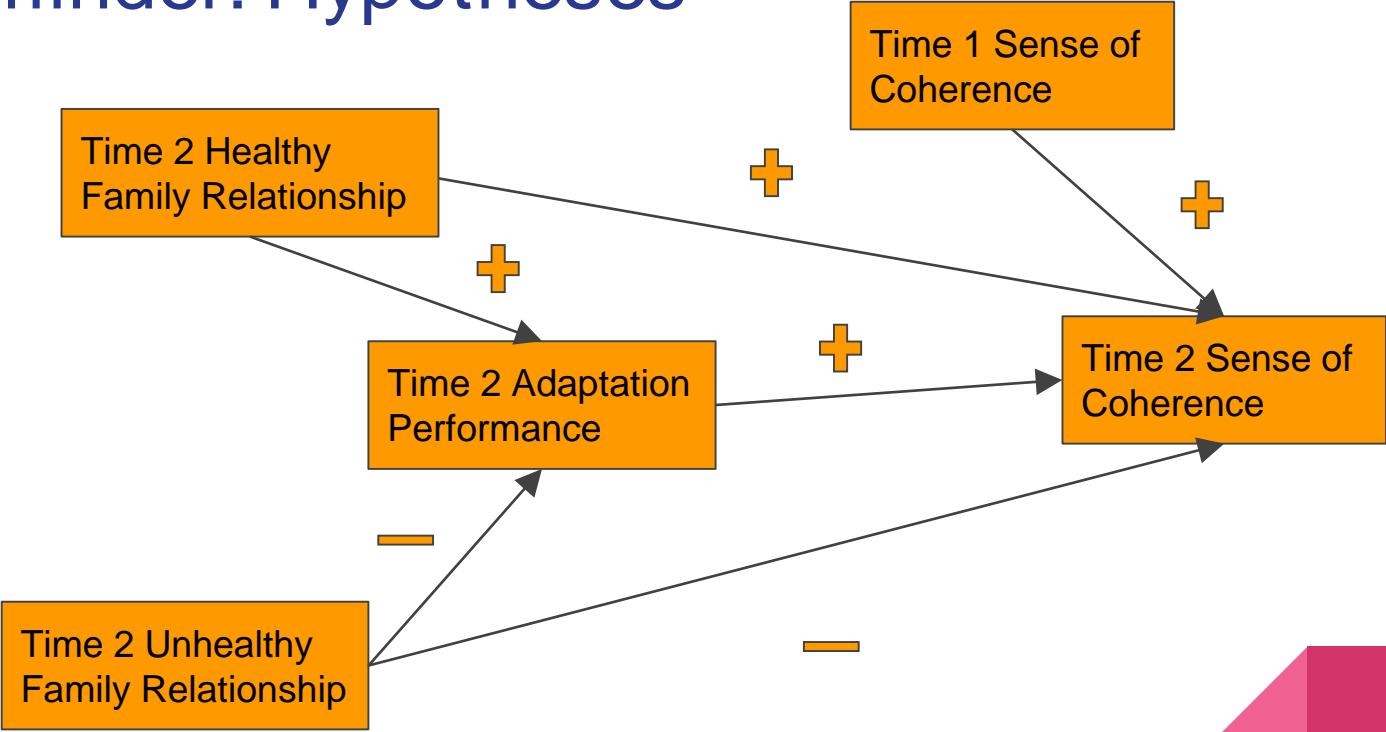

Method: Analysis

The hypothesized model was tested using:

Bivariate correlation analyses

Structural equation modeling



Outline

- Background
- Goal of Current Study
- Methods
- **Final model and Results**
- Discussion

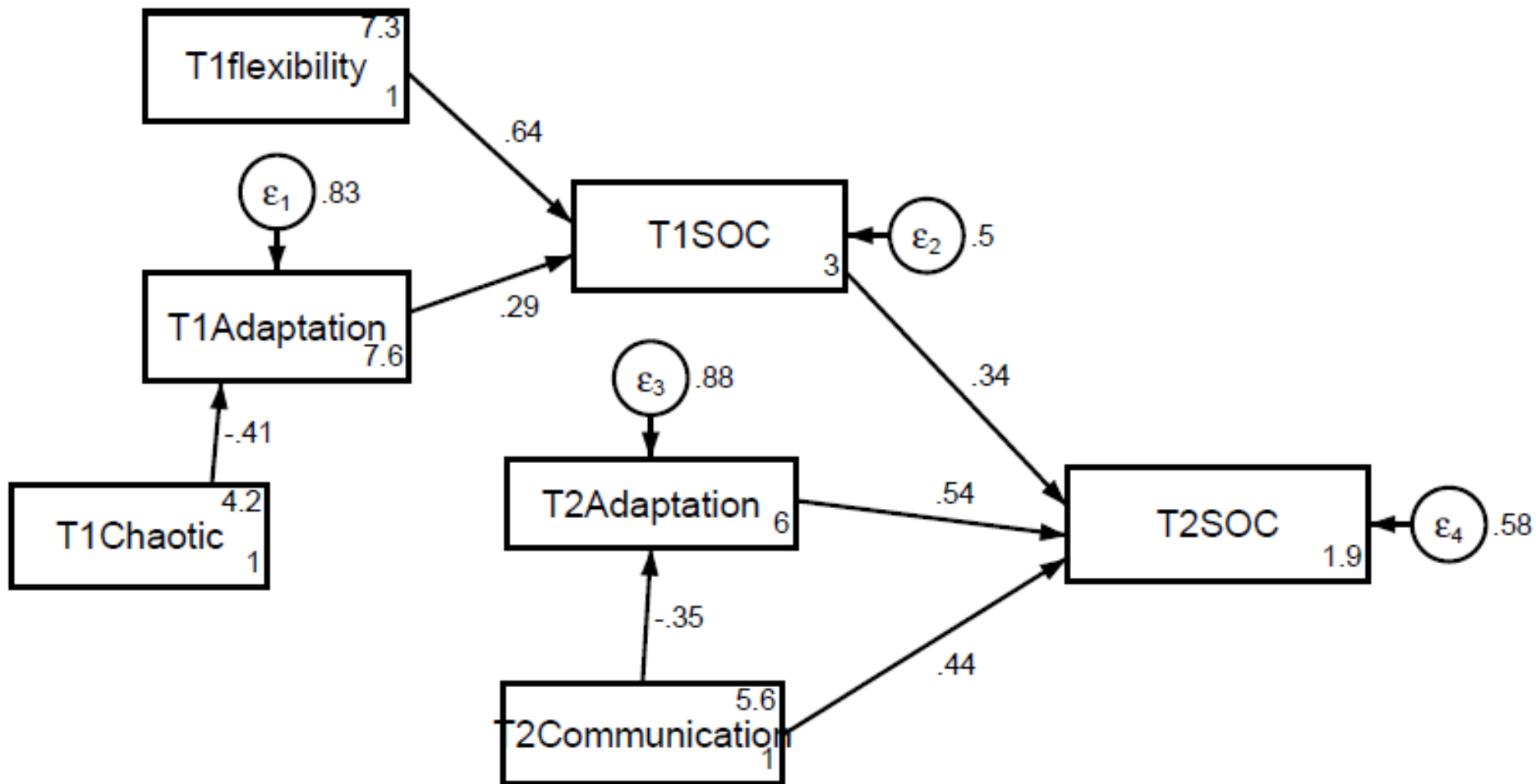

Final Model and example of variables in model

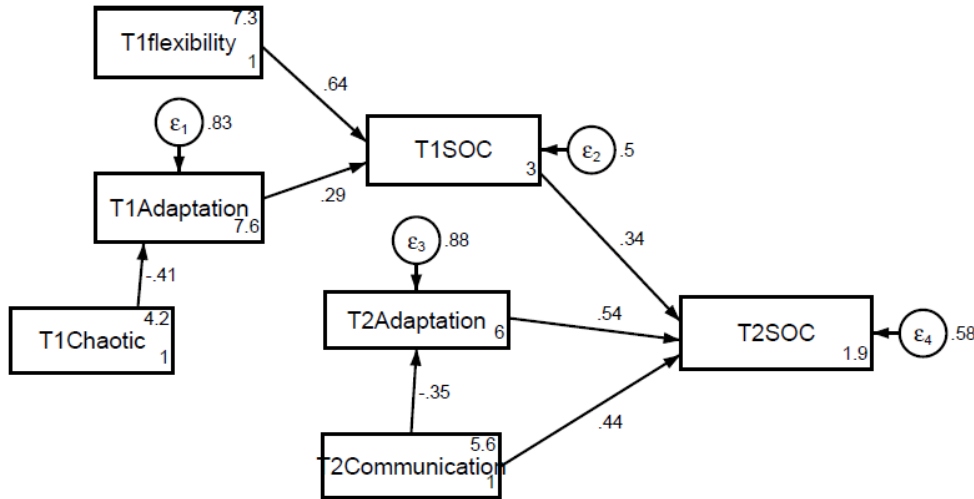

Unhealthy family relationship (**Chaotic**): “It is **hard to know** who the leader is in our family.”

Healthy family relationship (**Flexibility**): “Parents **equally share leadership** in our family. “

Healthy family relationship (**Communication**): “Family members are **very good listeners**.”

Adaptation performance: “Getting used to the **pace of life**.”

Sense of Coherence (**SOC**): “When you think of the **difficulties you are likely to face** in important aspects of your life, do you have the feeling that” rate from “I will **successfully overcome** it” to “I will **never overcome** it”

Results: Time 1

The model showed a good fit: The chi-square value was not significant, $\chi^2(11) = 11.477, p = .404$. **The other indexes also showed a good fit:** CFI = .991, TLI = .985, RMSEA = .036.

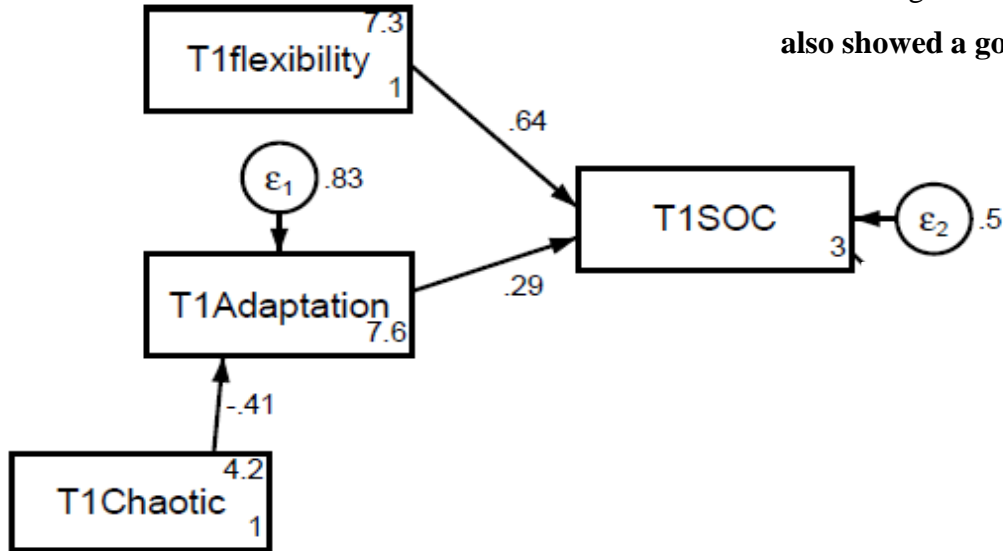

Results: Times 1 & 2

The model showed a good fit: The chi-square value was not significant, $\chi^2(11) = 11.477, p = .404$. The other indexes also showed a good fit: CFI = .991, TLI = .985, RMSEA = .036.

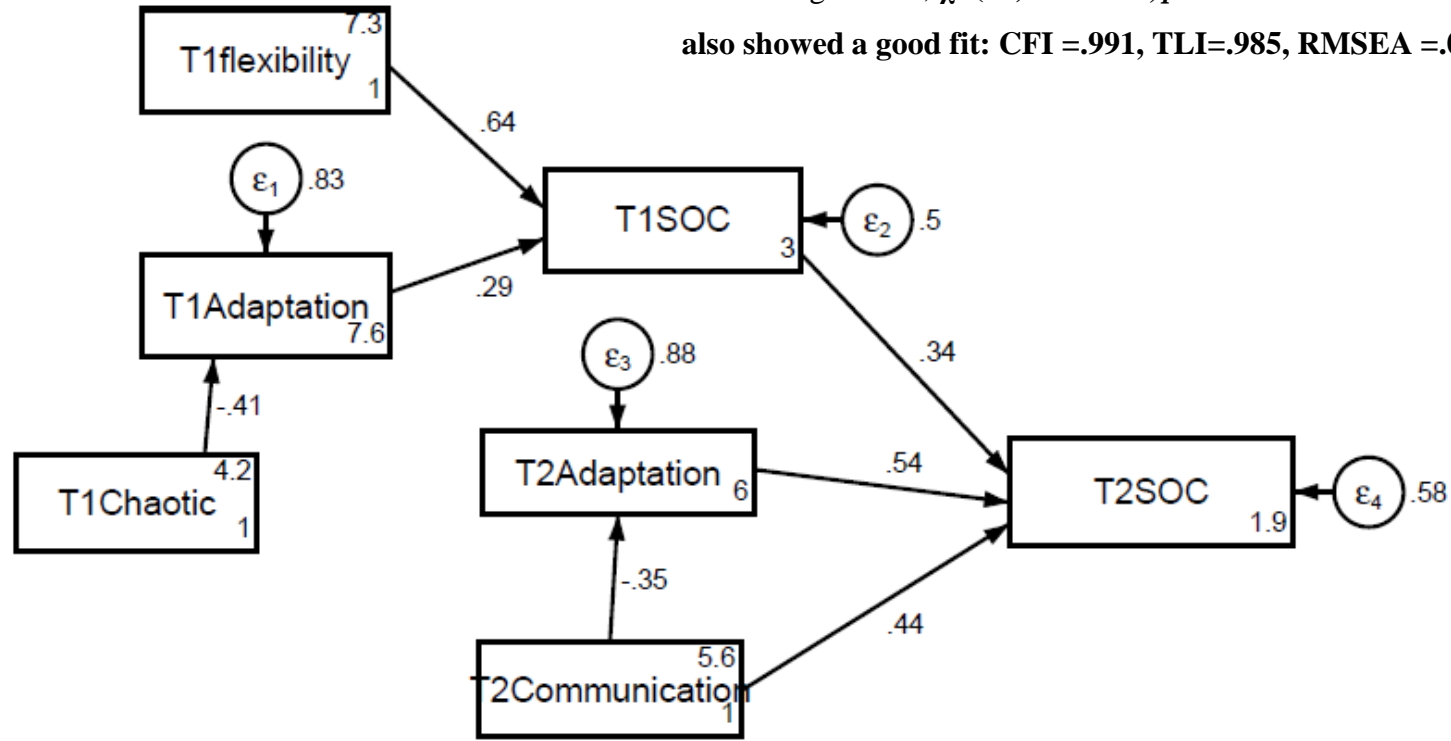

Outline

- Background
- Goal of Current Study
- Methods
- Final model and Results
- Discussion

Discussion: Time 1

- A. The **more well-organized** the family and the **better the adaptation**, the **stronger** the Sense of Coherence.
- B. The **weaker organization** of the family the **poorer** the adaptation performance.



Discussion: Time 2

- A. SAME AS TIME 1: The **more well-organized** the family and the **better the adaptation**, the **stronger** the Sense of Coherence.

- A. The **more support** from family communication the **poorer the adaptation performance**.
- B. Adaptation **mediates** the impact of family communication on Sense of Coherence.
- C. Sense of Coherence at Time 1 **predict** Sense of Coherence level at Time 2 in a positive way.





Limitations

Small sample

Qualitative data is needed





Implication

- Need for more research:
 - Examin **international students' SOC**
 - **Factors that contributes to mental health**
- Provide the university with **a better understanding on Chinese international students'** mental state in relation to their adjustment level for the sake of students' **health development** in UMM



Acknowledgements

Dr. Oscar Baldelomar

Culture and Human Development: Kali Tiernan, Keenan Cashen-Smart, Kaitlynn Roben, Tani White, Shannon Thompson

UROP program

International Student Program



Any Questions?



Thanks for Coming!

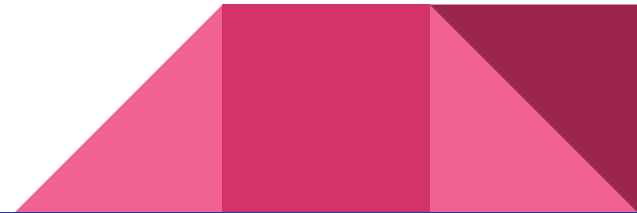

References

Antonovsky, A. (1979). *Health, stress and coping: New perspectives on mental and physical well-being*. San Francisco: Jossey-Bass.

Antonovsky, A. (1987a). *Unraveling the mystery of health. How people manage stress and stay well*. San Francisco: Jossey-Bass.

Antonovsky, A., Kalimo, R., Eltatawi, M., & Cooper, C. L. (Eds.) (1987b). *Psychosocial factors at work and their effects on health*. Geneva, Switzerland: World Health Organization.

Binkowska-Bury, M., & Januszewicz, P. (2010). SENSE OF COHERENCE AND HEALTH-RELATED BEHAVIOUR AMONG UNIVERSITY STUDENTS -A QUESTIONNAIRE SURVEY. *Central European Journal of Public Health*, 18(3), 145-50.



References

Cox, J. M., & Harter. S.M. K. (2003). *Parent-Child Relationship*. Mahwah: Lawrence Erlbaum Associates. Ben-David, A. (1996).

Cross-cultural differences between russian immigrants and israeli college students: The effect of the family on the sense of coherence. *Israel Journal of Psychiatry and Related Sciences*, 33(1), 13-20.

Darling, C. A., McWey, L. M., Howard, S. N., & Olmstead, S. B. (2007). College student stress: The influence of interpersonal relationships on sense of coherence. *Stress and Health: Journal of the International Society for the Investigation of Stress*, 23(4), 215-229.

Farruggia SP, Chen C, Greenberger E, Dmitrieva J, Macek P. Adolescent self-esteem in cross-cultural perspective: testing measurement equivalence and a mediation model. *J Cross Cult Psychol*. 2004;35(6):719-33.



References

- Feldt, T., Kokko, K., Kinnunen, U., & Pulkkinen, L. (2005). The role of family background, school success, and career orientation in the development of sense of coherence. *European Psychologist, 10*(4), 298-308.
- Furukawa, T. (1997). Depressive symptoms among international exchange students, and their predictors. *Acta Psychiatrica Scandinavica, 96*, 242–246.
- Ying, Y., Lee, P. A., & Tsai, J. L. (2007). Predictors of depressive symptoms in chinese american college students: Parent and peer attachment, college challenges and sense of coherence. *American Journal of Orthopsychiatry, 77*(2), 316-323.

